

Panther Mobile Hot Cupboards

Key Features

- Type: Electric
- Plain top/work surface
- Adjustable thermostatic temperature control
- Sliding doors to front (removable)
- Supplied with two shelves
- Supplied with swivel and lockable castors
- Supplied with mains flexi-cord (1 – 2M)
- Cupboard double skinned and insulated
- Supplied with push bar



GM3

Construction

- Body: stainless steel grade 430
- Interior: mirror stainless steel
- Chrome plated shelves

Available Options

- Choice of sizes

Available Accessories

- *DT2 – Digital temperature display
- *OG2/3 – Infra-red overhead gantry
- *TS2/TS3 – Drop down Tray slides
- *SN2/3 – Sneeze screen and overshelf
- *CB8 – Corner bumpers
- *PB16 – Additional push bar (*Factory fitted)

Specifications

Model	GM2	GM3
External height (mm)	900	900
External width (mm)	870	1190
External depth (mm)	650	650
Usable oven capacity h x w x d (mm)	435 x 740 x 510	435 x 1060 x 510
Oven shelf size w x d (mm)	731 x 510	1055 x 510
Net weight unpacked (kg)	65	88
Gross weight packed (kg)	78	96
Shipping volume (m ³)	1.043	1.136
Total electrical power rating (kW)	1.5	2.0
Electrical supply 1N~+E 230V 50-60Hz Current Rating (A)	6.3	8.4

GM2

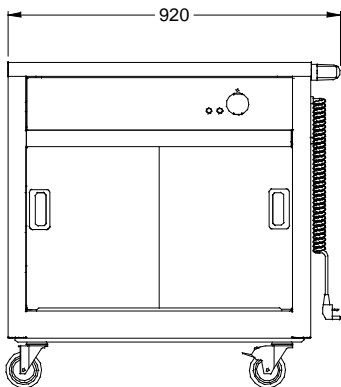
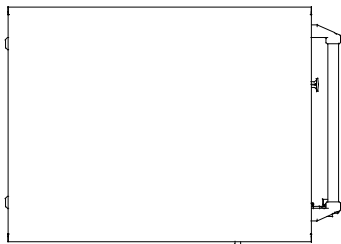

GM3

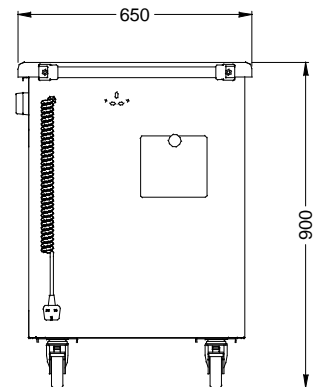
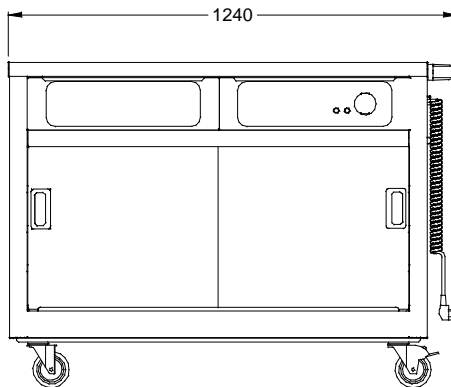
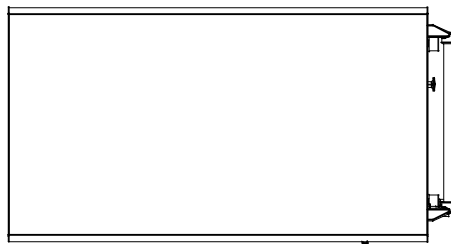

Lincat Limited, Whisby Road,
Lincoln LN6 3QZ,
United Kingdom

UK Sales Tel: 01522 875500 UK Spares Tel: 01522 875510 UK General Tel: 01522 875555
 UK Fax: 01522 875530 International Sales Tel: +44 1522 503250 International Fax: +44 1522 875530
 Website: www.lincat.co.uk UK Sales e-mail: sales@lincat.co.uk International Sales e-mail: export@lincat.co.uk



Document ref:
PANTHER-GM
Issue date: Oct-09